



Receiver Dynamic Range: Part 2

Part 1 of this article reviews receiver measurements which, taken as a group, describe receiver dynamic range. Part 2 introduces comprehensive measurements that attempt to characterize a receiver's dynamic range as a single number.

COMPREHENSIVE MEASUREMENTS

The following receiver measurements and specifications attempt to define overall receiver dynamic range as a single number which can be used both to predict overall receiver performance and as a figure of merit to compare competing receivers. They include: 1-dB compression dynamic range, desensitization dynamic range, spur-free dynamic range, and NPR (noise-power ratio) figure of merit (NPRFOM). In general, they are based on the primary measurements of receiver performance, but the NPRFOM test attempts to simulate the actual signal environment in a way that combines all of the receiver dynamic range characteristics (see Table 1). This test is proposed as a practical and realistic measurement of receiver dynamic range.

1-DB COMPRESSION DYNAMIC RANGE

The receiver 1-dB compression dynamic range defines the range of signal levels that

100 kHz	10 MHz
200 kHz	20 MHz
500 kHz	50 MHz
1 MHz*	100 MHz*
2 MHz	200 MHz
5 MHz*	500 MHz*
	1 GHz
*Recommended minimum set.	

Table 1. Recommended standard filter frequencies for NPRFOM measurements.

the receiver can process acceptably. In simplest terms, it is the difference in dB between the inband 1-dB compression point and the minimum-receivable signal level. The compression point is obvious enough; however, the minimum-receivable signal must be identified.

There are a number of candidates for minimum-receivable signal level, including: "minimum-discernable signal" (MDS), tangential sensitivity, 10-dB SNR, and receiver noise floor. Both MDS and tangential sensitivity are based on subjective judgments of signal strength, which differ significantly from author to author. They are mentioned here because of their historical significance, but the uncertainty limits their value as a part of receiver dynamic-range specifications. A more repeatable measurement is 10-dB SNR; but this, too, has disadvantages because of the variations of SNR due to type and percentage of modulation. The least ambiguous indicator of minimum receivable signal is probably receiver noise floor. This can be defined in two ways: noise floor in a 1-Hz bandwidth and total equivalent input noise power in the narrowest receiver bandwidth. The first is simply -174 dBm plus the receiver noise figure in dB; while the second has the additional factor of 10 times the log of the receiver bandwidth. For most purposes, the inclusion of the receiver bandwidth yields a better estimator of usable dynamic range. Using this definition, receiver dynamic range can be expressed as:

$$CDR = P_{ic} + 174 \text{ dBm} - 10 \log BW - NF$$

where:

- CDR is the compression dynamic range in dB
- P_{ic} is the 1-dB input compression power in dBm
- BW is the narrowest receiver bandwidth in Hz

NF is the receiver noise figure in dB

This dynamic range definition has the advantage of being relatively easy to measure without ambiguity but, unfortunately, it assumes that the receiver has only a single signal at its input and that the signal is desired. For deep-space receivers, this may be a reasonable assumption, but the terrestrial sphere is not usually so benign. For specification of general-purpose receivers, some interfering signals must be assumed, and this is what the other definitions of receiver dynamic range do.

DESENSITIZATION DYNAMIC RANGE

Desensitization dynamic range (DDR) measures the receiver degradation effects due to a single, dominant, out-of-band interferer. In many "real world" signal environments, a single, strong signal may be the major source of interference due to the effects of receiver phase noise and out-of-band signal compression. In this test, a signal that produces an output SNR of 10 dB is injected at the receiver input. An interfering sinusoid is added to the input at a particular frequency offset from the tuned frequency and its magnitude is increased until the output SNR degrades 1 dB. The DDR is then the power ratio (in dB) of the undesired signal power (in dBm) to the receiver noise floor in dBm per Hertz. The DDR can be calculated using the equation:

$$DDR = P_i - NF + 174$$

where:

- DDR is the desensitization dynamic range in dB
- P_i is the interfering signal power in dBm
- NF is the receiver noise figure

DDR is a true measure of dynamic range because it includes both noise figure and



measurement of overload/ interfering signal power. The use of receiver input attenuation will improve large signal-handling capability, but noise figure will be degraded commensurately. The DDR, however, is not affected by input attenuators. When it is desirable to determine the absolute signal power in dBm required to cause desensitization for a particular receiver configuration, the following equation can be used:

$$P_i = \text{DDR} + \text{NF} - 174$$

Note that the noise figure must include the effects of input attenuation as the receiver is intended to be used.

DDR is strongly affected by the frequency offset of the interfering signal. At small frequency offsets, the DDR is dominated by the effects of receiver phase noise reciprocal mixing. In this region, the DDR is approximately 6 dB less than the magnitude of the single-sided phase noise spectrum in dB per Hertz below the "carrier" (dBc). For example, if a receiver's phase noise at 100 kHz from the tuned (carrier) frequency is -130 dBc, the DDR at 100 kHz offset will be about 124 dB. In general, receiver phase noise improves with frequency offset so that in some receivers, interfering signals well removed from the tuned frequency, will begin to cause signal compression before the effects of phase noise reciprocal mixing are observed. In this case, the DDR will be worse than 6 dB less than the magnitude of the phase-noise suppression at these frequencies. Because of these frequency effects, it is necessary to specify the DDR at several different offset frequencies. The best presentation of this data would be in the form of a graph, as shown in Figure 1.

This figure compares the DDR of three popular vhf/uhf receivers. At small frequency offsets, the DDR is typically dominated by receiver phase noise. At larger frequency offsets, in receivers with modest signal input filtering (rf preselection) 1 dB compression due to signal overload may occur. This is the

effect seen in both the XX-R7000 and XXX-500 receivers.

The significance of DDR is somewhat dependent on signal environment. If the interfering signals have significant phase noise of their own, it is only necessary for the receiver's phase noise to be better than the interferer's. Most radio transmitters have significant amounts of phase-noise sideband energy at modest offsets from the carrier frequency. This is especially true for variable frequency oscillator (vfo) and most frequency-synthesized frequency sources. A notable exception, which may have very low levels of small offset phase noise, is crystal oscillator signal sources. At large frequency offsets, many transmitters will have low phase noise because of the filtering properties of tuned power output stages and narrow antenna bandwidths. For this reason, more attention should be given to obtaining a good DDR at large frequency offsets.

A test setup for DDR measurement is shown in Figure 2. The receiver is tuned to the test frequency and set for maximum gain in the narrowest available bandwidth with a bfo detection mode. In some receivers, it will be necessary to use the ssb mode to activate the bfo and to achieve narrow bandwidth. The

receiver is tuned to center the test signal in the IF passband and to produce an audio "beat note" of 1 kHz.

If the receiver does not have a "predetection" demodulation mode like "cw" or ssb which uses a bfo frequency conversion to audio, the narrowest available IF output may be used with a spectrum analyzer. In this case, the signal is monitored for a 1-dB amplitude decrease due to compression, and the noise floor is monitored for a 1-dB increase due to phase-noise reciprocal mixing.

The interfering signal generator must have phase noise much better than that of the receiver under test. The tunable bandpass filter will help eliminate any residual generator phase noise at large frequency offsets. The audio lowpass filter is not required, but serves to minimize the effects of variations in audio response from receiver-to-receiver.

SPUR-FREE DYNAMIC RANGE

Spur-free dynamic range (SFDR), as generally used, attempts to define receiver dynamic range in terms of two undesired interferers and the receiver noise floor. As with the 1-dB compression dynamic range, it is based on a mathematical manipulation of the primary measurements of receiver range. In this

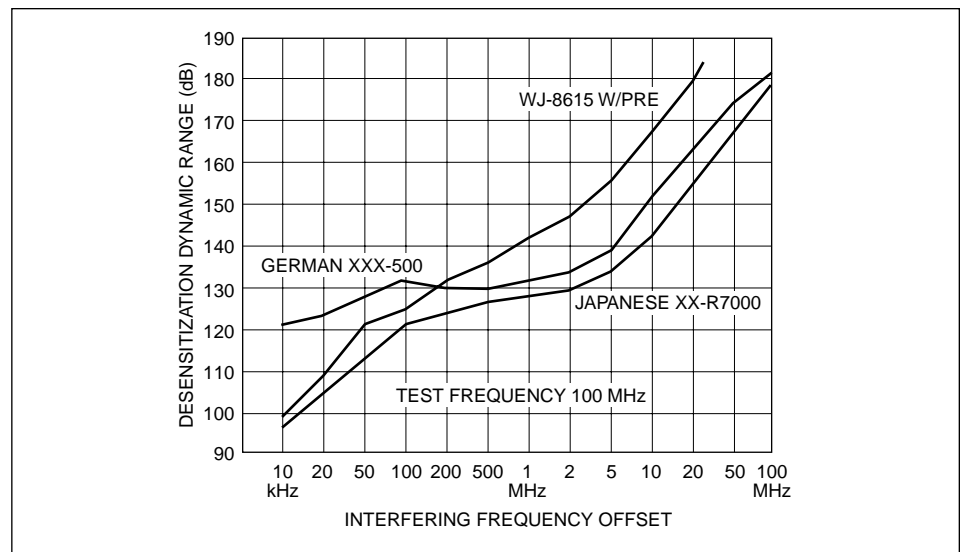

Figure 1. Desensitization dynamic range (DDR) as a function of frequency offset of the interfering signal.

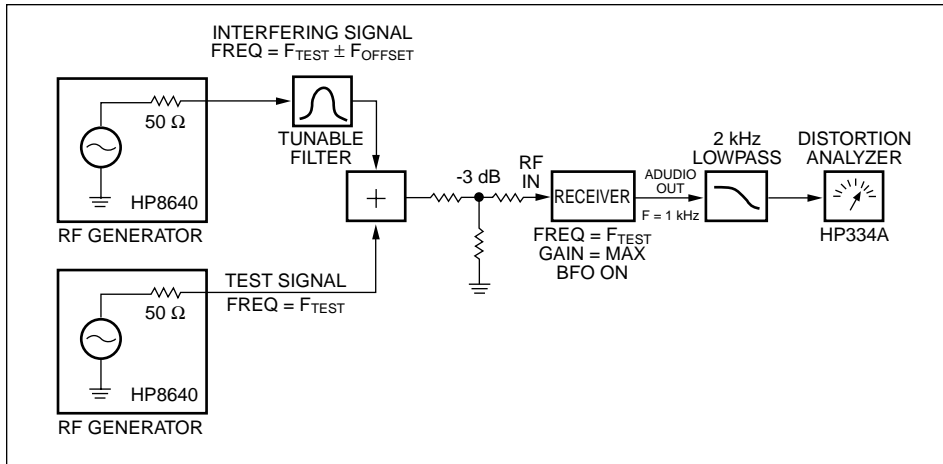

Figure 2. Desensitization dynamic-range test configuration.

case, the spur-free dynamic range is the difference in dB between the receiver noise floor and the level of each of two equal-amplitude, out-of-band interfering tones that produce an in-band spurious product equal in power to the noise floor. Generally, the receiver third-order intercept point is used to predict the spurious product, but often the second-order distortion dominates. In any case, the SFDR can easily be expressed as:

$$SFDR_3 = 2/3 (IIP_3 + 174 - NF - 10 \log BW)$$

or

$$SFDR_2 = 1/2 (IIP_2 + 174 - NF - 10 \log BW)$$

where:

- SFDR₃ is the third-order spur-free dynamic range in dB
- IIP₃ is the receiver third-order input intercept point in dBm
- NF is the receiver noise figure in dB
- BW is the narrowest receiver bandwidth in Hz
- SFDR₂ is the second-order spur-free dynamic range in dB
- IIP₂ is the receiver second-order input intercept point in dBm

Spur-free dynamic range has become a very popular specification because it seems to give a single number which can be used to compare the overall dynamic-range performance of competing receivers. Unfortunately, the

SFDR specification overlooks several important factors which influence dynamic range. First, it attempts to model interference by using just two interfering signals. This overcomes some of the objections to single-tone testing, but the real signal environment is usually populated by a multitude of signals. Second, it does not reveal the effects of reciprocal mixing or compression like the desensitization dynamic-range test. Third, it does not effectively test the effects of receiver input filtering (preselection). Finally, SFDR, as it is ordinarily specified, considers only the third-order distortion. In fact, for many receivers, especially those with modest input filters, the second-order products may dominate. For example, for a receiver with a bandwidth of 100 Hz, a noise figure of 10 dB, a third-order intercept of +20 dBm, and a second-order intercept of +50 dBm, the second- and third-order SFDRs will be 97 dB and 109.3 dB, respectively. Surely, the lesser of the two values is more valid; however, it is often not specified.

Because spur-free dynamic range is derived from the primary measurements, it would seem to provide no new information. Instead, it merely adds to the confusion of receiver dynamic range specifications. However, there is a continuing need - or at least a desire - for a truly comprehensive measurement of receiver dynamic range. A

possible candidate is the NPR figure-of-merit (NPRFOM).

NPR FIGURE OF MERIT

The NPR figure-of-merit dynamic range measurement attempts to overcome some of the shortcomings of earlier measurements by better simulating the signal environment with high-power white noise.

NPR is an abbreviation for Noise Power Ratio, a term familiar to those involved in FDM telephone work. NPR testing simulates the signal environment by a broad band of “white noise with the total noise power adjusted to equal the total signal power that can be expected at the receiver input. The noise is removed at the receiver’s tuned frequency by a notch filter. Due to receiver distortion, this notch tends to fill with intermodulation products. The apparent notch depth, as seen by the receiver, is the noise power ratio; that is, the ratio of out-of-notch noise to in-notch noise measured in dB (see Figure 3). This test has been used for many years in FDM telephone measurements and is specified by the CCIR and CCITT.

NPRFOM is defined as the sum of the input noise spectral density which produces a receiver NPR of 40 dB plus 174 dB minus the receiver noise figure. For this measurement, noise figure is measured at the manual gain setting, which produces nominal receiver output when tuned to the notch frequency. NPRFOM can be expressed as:

$$NPRFOM = P_{npr} + 174 - NF$$

where:

- NPRFOM is the Noise Power Ratio Figure of Merit in dB
- P_{npr} is the input power spectral density in dBm/Hz for the white noise that produces a 40 dB NPR
- NF is the receiver noise figure in dB measured at the receiver-gain setting which produces the nominal receiver output in the nar-



lowest available predetection output

The 40-dB value for NPR was chosen because it is somewhat inconvenient to obtain noise sources with notch depths significantly greater than -50 dB.

Noise figure is included in the NPRFOM to give a relative indication of receiver dynamic range. It is measured with receiver gain set for a nominal output when tuned to the noise notch because this eliminates the effects of receiver input attenuation. Adding attenuation to the input of a receiver linearity increases its power-handling capability, but adding attenuation also linearly increases the receiver noise figure. Consequently, there is no net change in receiver dynamic range due to input attenuation. The factor of 174 dB normalizes the measurement to the theoretical noise floor of -174 dBm/Hz. The NPRFOM measurement produces a single measurement of dynamic range which can be used to directly compare the effective performance of competing receivers. This comparison is not affected by the nonideality of third-order intercept extrapolations, or by the vagaries of preselector specifications, but instead highlights the differences between receivers that appear in operation, but not on a manufacturer's data sheet.

A basic NPRFOM test setup is shown in Figure 4. The test is performed using the following step-by-step procedure (Steps 1,2 and 3 preset the receiver and the noise level):

1. Set the receiver for the minimum available bandwidth and a predetection mode (CW or SSB). Monitor the audio output level with the meter. If these predetection modes are not available, monitor the narrowband IF output. Set the audio gain for mid-range and tune the receiver to a frequency outside of the notch.
2. Set the attenuator for maximum and temporarily disconnect the noise source. Increase the receiver RF/IF gain until the meter indicates -3 dB with respect to the

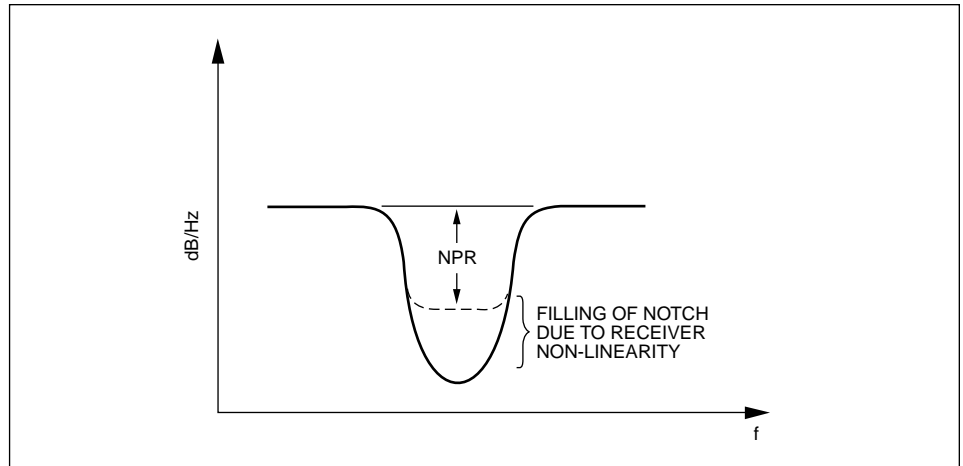

Figure 3. Noise power ratio (NPR).

3. Reconnect the noise source and decrease the attenuation until the nominal output level is indicated on the meter.

Now that the receiver and test setup have been preset, Steps 4, 5 and 6 are repeated until the noise level at the receiver input produces a 40-dB NPR.

4. Tune to the notch frequency and decrease the attenuation by 40 dB. If the output is less than the nominal level, go to Step 5. If the output is equal to the nominal value, go to Step 7. If the output is greater than the nominal value, the receiver has insufficient dynamic range to achieve an NPR of 40 dB.

5. Decrease the attenuation until the output is at the nominal level.
6. Tune the receiver to a frequency outside of the notch and increase the attenuation by 40 dB. Adjust the receiver manual gain for nominal output and return to Step 4.

Steps 7 and 8 measure the noise level and receiver noise figure which are then used to calculate NPRFOM.

7. Without changing the receiver settings, disconnect the signal from the receiver input and measure the out-of-notch noise spectral density at the attenuator output with a spectrum analyzer. Enter this value into the NPRFOM equation.
8. Without changing the receiver settings, measure the receiver noise figure. Enter this value into the NPRFOM equation and calculate NPRFOM.

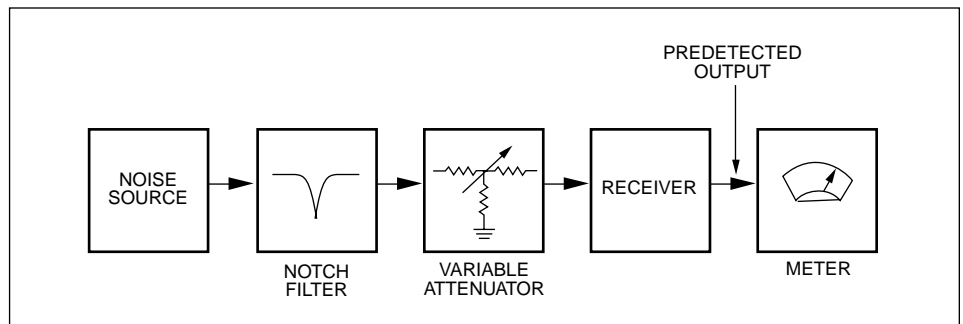

Figure 4. NPRFOM test configuration.



The measured values for NPRFOM are somewhat dependent on the test configuration. While the relative ranking of several receivers is generally unaffected by the test configuration, direct comparisons of NPRFOM values are possible only when the test conditions are standardized. In particular, the characteristics of the notch filter and noise source must be specified.

The noise source must be spectrally “flat” or “white.” A desirable limit of noise amplitude spectrum flatness is 1 dB. The band-of-noise frequencies, in the most desirable case, would cover the range from less than one-third the receiver’s lowest tunable frequency to greater than twice the highest tunable frequency. For wide-tuning receivers, this range may be difficult to obtain. A more reasonable noise frequency range would be from one-third the test frequency to two times the test frequency. For some receiver frequencies, noise generator limitations make an even more restricted noise bandwidth necessary. In this case, a noise band covering the range of ±25% of the tuned frequency is recommended.

The notch filter is the most critical component of the test configuration. The ideal notch filter would have a -3 dB bandwidth only slightly wider than the receiver final IF bandwidth, and a -50 dB bandwidth equal to the final IF bandwidth. Such a narrow notch would allow the noise to simulate a uniformly dense signal environment. This would also maximize the test’s ability to discriminate between the performances of differing receivers. This is because a narrow notch maximizes the stress on the receiver’s input filter and first IF stages. Unfortunately, the component Q’s for such a filter would make it difficult or impossible to realize. It is more practical to use a set of standardized filters similar to those specified by the CCITT for FDM NPR measurements. These filters typically have -3 dB bandwidths, which are a constant percent of their center frequencies. The constant percent band-

width characteristic tends to produce NPRFOM values which do not vary greatly with test frequency. Also, this type of filter can be realized with limited values of component Q. Figure 5 gives recommended bandwidth values for both LC filters and crystal filters. Table 1 lists recommended center frequencies. Where feasible, the narrower crystal filters are preferred for the reasons stated above. These filters are relatively simple, but a full set is somewhat expensive. Lower-cost notch filters are shown in Figures 6 and 7.

The LC filter of Figure 6 is most useful for frequencies below 50 MHz. It is relatively easy to construct and requires components of only modest Q. The capacitor values are specified to produce constant percentage bandwidth of approximately 6%. The inductor should have a Q greater than 50 and the capacitors should be matched within 5%.

The delay-line filter of Figure 7 is most useful for frequencies from 50 to 1000 MHz. Its major advantage is repeatability, but a major disadvantage is the production of multiple notches (Figure 8). However, the

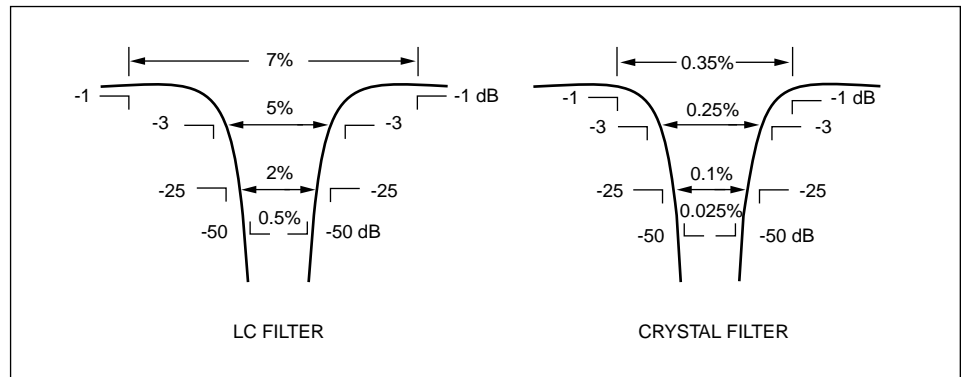

Figure 5. Recommended notch-filter bandwidths for NPRFOM measurements.

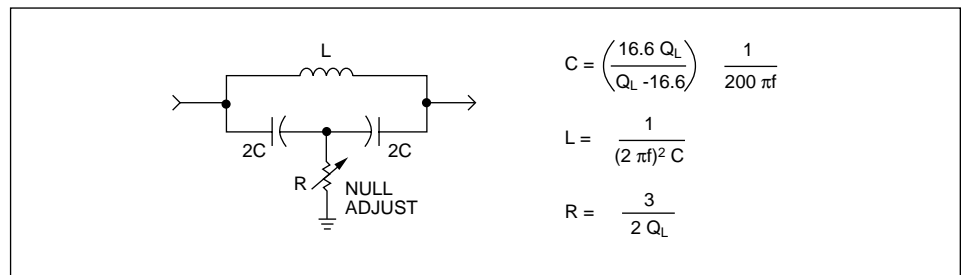

Figure 6. Notch filter with 6%, -3 dB bandwidth for 50-ohm source and load.

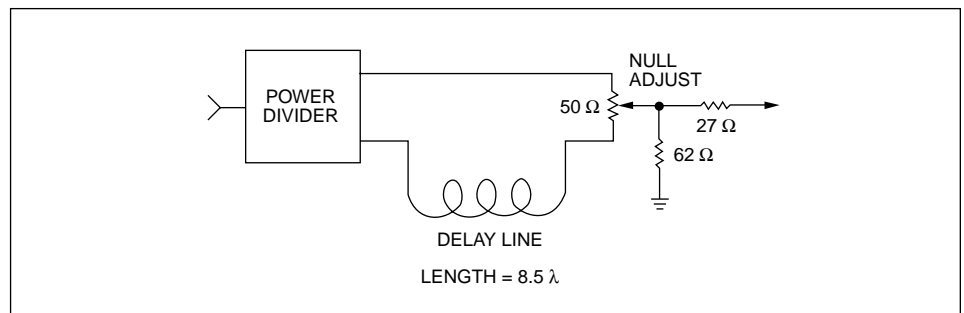

Figure 7. Delay-line notch filter.



power loss due to the extra notches is only about 2.5 dB, and this small amount can be subtracted from the resulting NPRFOM measurement without causing a major error. The ninth notch in the series (counting from zero frequency), was selected for this test because it is a reasonable compromise considering notch -3 dB bandwidth, -50 dB bandwidth, and cable loss. Higher notch numbers have narrower -3 dB bandwidths, but the -50 dB bandwidth becomes very narrow and the increased cable length causes excessive frequency loss “tilt.” For the ninth notch, the -3 dB bandwidth is approximately 6.06% of the center frequency, and the -50 dB bandwidth is approximately 0.024% (see Figure 9). The out-of-notch frequency for measuring noise spectral density and for tuning during the NPRFOM test is at plus or minus 6% from the notch frequency. These frequencies correspond to the nearest filter transfer maxima.

The effectiveness of NPRFOM in differentiating the dynamic range performance can be seen in Table 2. Several communications quality vhf/uhf receivers were tested for NPRFOM using filters similar to those in Figure 6. The differences in performance can be readily explained by the differences in receiver design. Receiver A is a proven, older design which was optimized for low noise

figure. The first stage of preselection is low loss and rather broad. Also the tube-technology input amplifier does not have the signal-handling capability of more modern high dynamic-range designs. Receiver B is a com-

pact vhf/uhf receiver, without the preselector option, is overloaded by the broadband input noise because of both second- and third-order intermodulation effects. Receiver C has a modest tracking preselector, but its

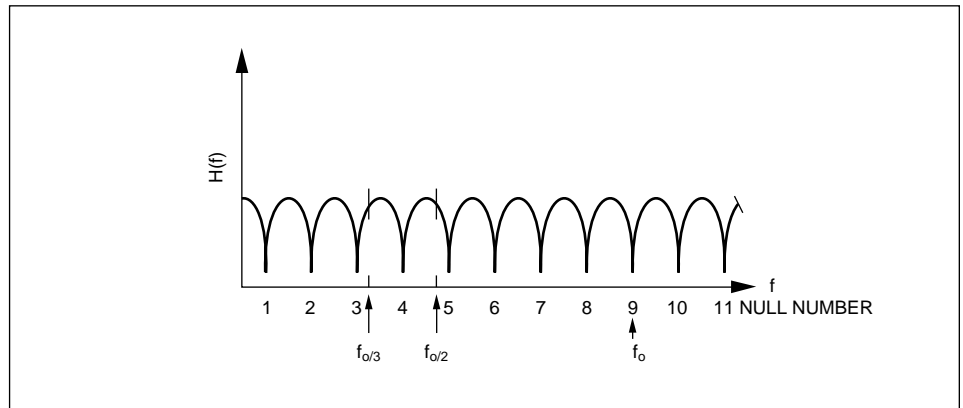

Figure 8. Frequency response of delay-line filter.

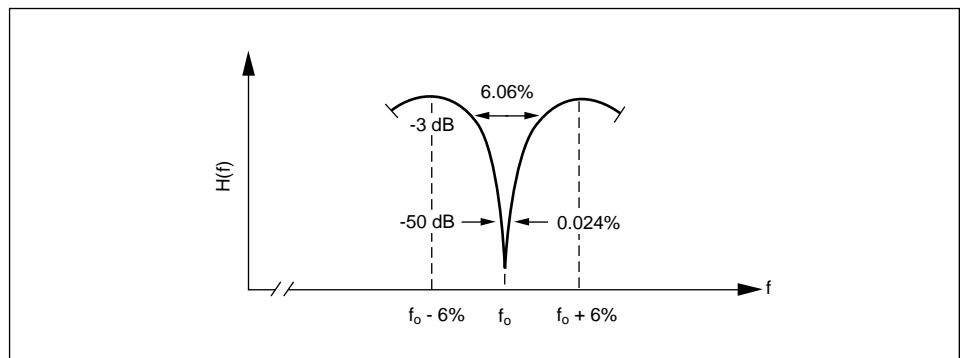

Figure 9. Detail of delay-line filter frequency response for ninth null.

Receiver	Configuration	Noise PWA dim/Hz For 40 dB NPR		Noise Figure at Test Gain		NPRFOM (dB)	
		@39 MHz	@111 MHz	@39 MHz	@111 MHz	@39 MHz	@111 MHz
A	Normal	-118	-114	5	5.5	51	54.5
B	No Preselector	-99	-104	10	10	65	60
C	Normal	-95	-98.5	13	13	66	62.5
D	Normal	-88	-82	8.5	9	77.5	77
E	Normal	-83	-86	10	10	81	78
F	External Suboctave Preselector	-86	—	7	—	81	—
G	Tracking Preselector	-82	-82	10	10	82	81
H	Internal Tracking Preselector	-77	-79	10	10	87	85

Table 2. NPRFOM measurements for several communications receivers.



poor third-order performance allows only a slight improvement in NPRFOM. Receiver D performs much better due to its internal switched suboctave preselector and very good third-order performance. The Receiver E performs slightly better than D receiver because it has a tracking preselector which is slightly narrower than a switched suboctave preselector. Receiver F, with an external suboctave filter, has a NPRFOM similar to E because it has a significantly better noise figure. Receiver G has significantly improved dynamic range because of the relatively narrow bandwidth of the tracking preselector. Finally, receiver H, with the tracking preselector option, performs best of all. This is because the preselector eliminates most of the broadband noise of the test signal. In addition, because the preselector is integral to the receiver, the entire signal path has been optimized for maximum dynamic range.

CONCLUSION

Satisfactory assessment of receiver dynamic range requires careful measurement of sever-

al parameters. The primary receiver measurements of noise figure, second-order intercept, third-order intercept, 1-dB compression, phase noise and internal spurious signals can provide information for determining receiver dynamic range. Secondary receiver measurements, such as sensitivity, cross modulation, intermodulation distortion, and reciprocal mix, can provide supplemental information, but they should not be substituted for the primary measurements. Comprehensive measurements of receiver dynamic range include noise-power ratio figure-of-merit and desensitization dynamic range. Together, these two measurements and the noise figure give an excellent indication of receiver dynamic range.

REFERENCES

The following list of books and articles represents a sampling of the more readable literature relating to the subject of this paper.

1. Grebenkemper, C. John, "Local Oscillator Phase Noise and Its Effect on Receiver Performance," Tech-Notes, Vol. 8 No. 6,

November/December 1981.

2. Dexter, Charles E., "Digitally Controlled VHF/UHF Receiver Design," Tech-Notes, Vol. 7 No. 3, June 1980.
3. McDowell, Rodney K., "High Dynamic Range Receiver Parameters," Tech-Notes, Vol. 7 No. 2, March/April 1980.
4. Erst, Stephen J., Receiving Systems Design, Artech House, 1984.
5. Hsieh, Chi, "GaAs FET IMD Demands Better Standard," Microwaves, Vol. 21 No. 6, June 1982.
6. Hirsh, Ronald B., "Knowing the Meaning of Signal-To-Noise Ratio" Microwaves and RF, Vol. 23 No. 2, February 1984
7. Fisk, James R., "Receiver Noise Figure Sensitivity and Dynamic Range - What the Numbers Mean," Ham Radio, October 1975.
8. Schwartz, Mischa, Information Transmission, Modulation and Noise, McGraw-Hill, 1980.