

WATKINS-JOHNSON COMPANY
3333 HILLVIEW AVENUE
PALO ALTO, CA 94304-1204
(415) 493-4141

ADDRESS CORRECTION REQUESTED

BULK RATE
U.S. POSTAGE
PAID
PERMIT
#1
SAN JOSE
CALIFORNIA



WATKINS-JOHNSON

Facility Locations

United States

CALIFORNIA

Watkins-Johnson
3333 Hillview Avenue
Palo Alto, 94304-1204
Telephone: (415) 493-4141

Watkins-Johnson
2525 North First Street
San Jose, 95131-1097
Telephone: (408) 435-1400

Watkins-Johnson
440 Kings Village Road
Scotts Valley, 95066-4081
Telephone: (408) 438-2100

Watkins-Johnson
214 East Gutierrez Street
Santa Barbara, 93101-1705
Telephone: (805) 965-1013

MARYLAND

Watkins-Johnson
700 Quince Orchard Road
Gaithersburg, 20878-1794
Telephone: (301) 948-7550

Watkins-Johnson
8530 Corridor Road
Savage, 20763
Telephone: (301) 497-3900

NORTH CAROLINA

Watkins-Johnson
100 West Powell Road
Fuquay-Varina, 27526-9399
Telephone: (919) 552-6161

International

UNITED KINGDOM

Watkins-Johnson
Deoworth Road
Berkshire
Windsor, Berkshire SL4 4LH
Telephone: 753 869241
Telex: 847 578
Cable: WJUKW-WINDSOR
Telefax: 753 841534

ITALY

Watkins-Johnson S.p.A.
Piazza G. Marconi 25
00144 Roma-EUR
Telephone: 6 592 4554
Telex: 6 591 2515
Cable: 612 278
Cable: WJ ROM I

GERMANY, FEDERAL REPUBLIC OF

Watkins-Johnson
Boschstr. 10
8039 Puchheim
Telephone: 89 802087/88
Telex: 529 401
Cable: WJDBM-MUENCHEN
Telefax: 89 803044

The Watkins-Johnson *Tech-notes* is a bi-monthly periodical circulated to educational institutions, engineers, managers of companies or government agencies, and technicians. Individuals may receive issues of *Tech-notes* by sending their subscription request on company letterhead, stating position and nature of business to the Editor, *Tech-notes*, at Watkins-Johnson's Palo Alto, California address. Permission to reprint articles may also be obtained by writing the Editor.

CASCADED AMPLIFIERS

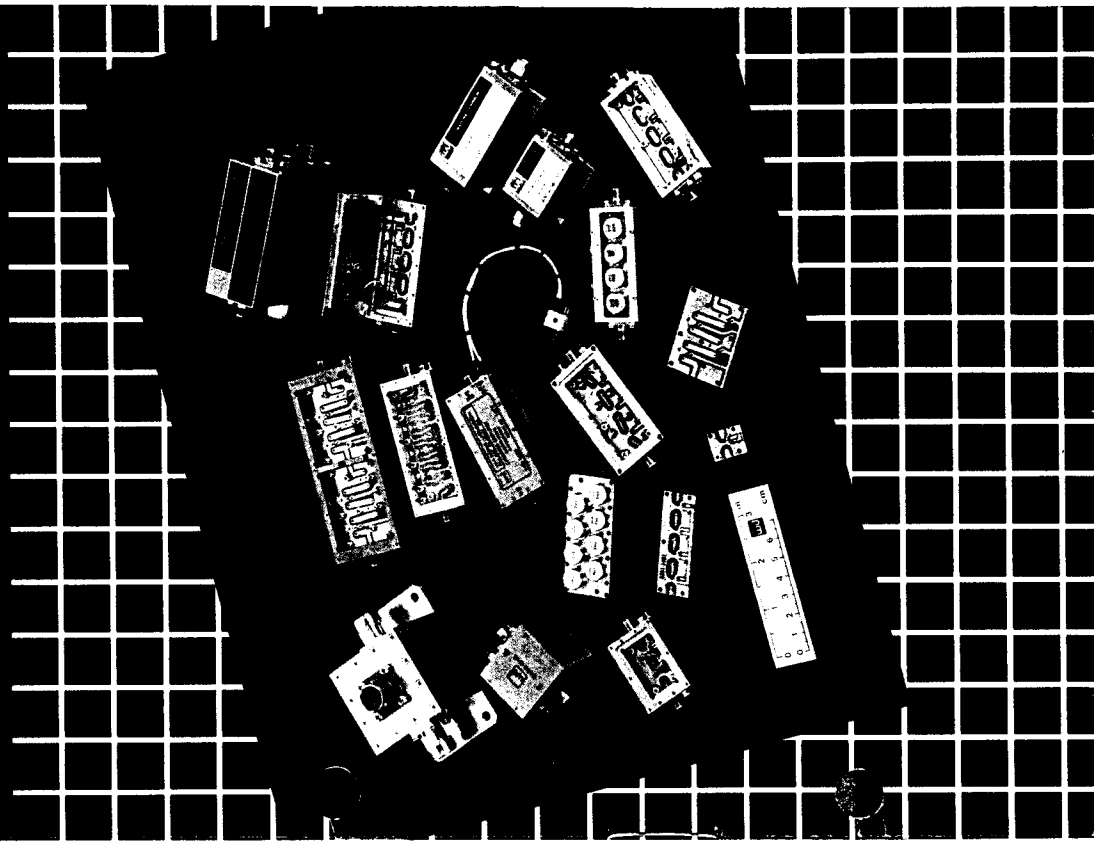

Cascadable TO-8 amplifiers, limiters and voltage-controlled attenuators, offer the circuit designer a high level of flexibility for system applications. Cascading TO-8 amplifiers onto microstrip printed wiring boards in connectorized housings reduces overall system complexity and increases system reliability. Unlike purchasing TO-8 amplifiers separately and assembling the units for multistage applications, the cascaded gain block is already assembled, tested and guaranteed to meet the desired electrical specifications.

The main objective of this article is to help develop a practical understanding of the challenges involved in the design, development, and production of cascaded amplifiers.

Operational Analysis

TO-8 amplifiers are initially designed with input/output matching circuitry to have a 50-ohm impedance. In production, due to component (transistors, capacitors, inductors, resistors) tolerances, impedance levels may not be exactly 50 ohms. In addition, inherent losses exist from thin-film circuit/TO-8 package interfacing. Before being sealed, these TO-8 amplifiers are manually tuned to compensate for offset impedance levels and unrecoverable losses so that the best possible broadband performance can be obtained. In a cascaded assembly, TO-8 amplifiers are first mounted onto a printed-wiring board (PWB) by means of silver-conductive epoxy preforms (see Figure 1) and then assembled into a connectorized housing. As effective as this interfacing technique is, additional degradations may still exist.

The trace on the printed wiring board links the input/output ports of the TO-8 amplifiers in cascade. Between the trace and the bottom ground conductor is a dielectric layer which has a dielectric

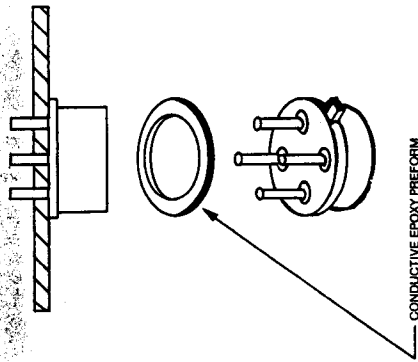

Figure 1. TO-8 mounting technique for cascaded amplifiers.

constant associated with it (see Figure 2). The rf trace dimensions (primarily width) are determined in relation to this dielectric constant and substrate thickness to obtain a 50-ohm impedance. Inherent in the cascaded assembly are parasitic inductive and capacitive reactances which tend to offset the 50-ohm transitions from stage-to-stage, especially at higher frequencies. The effect of more impedance mismatching between the cascaded assembly and the load results in more power being reflected back to the source. This can affect the small-signal gain ripple of a cascade as a midband dip or high-end frequency roll-off, since amplitudes of these fluctuations are dependent on the amount of reflected power.

In cases where optimum performance is required (for example, gain to be within a restricted gain window with minimal ripple), individual TO-8 amplifiers can be matched in a multistage test fixture (see Figure 3) prior to cascade assembly. Here, 50-ohm interfacing between stages is optimized, yielding minimal offset. In extreme cases, where TO-8 amplifiers will not effectively match in cascade, individual amplifier circuitry can be tuned at TO-8 preaseal (before the

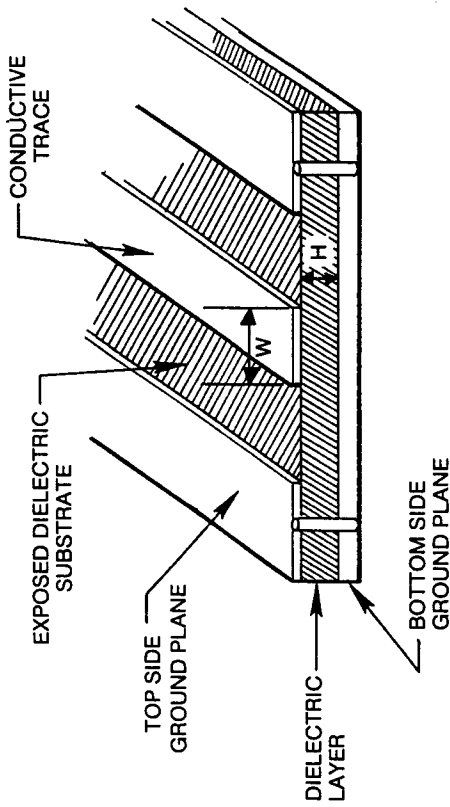

Figure 2. Printed-wiring board description.

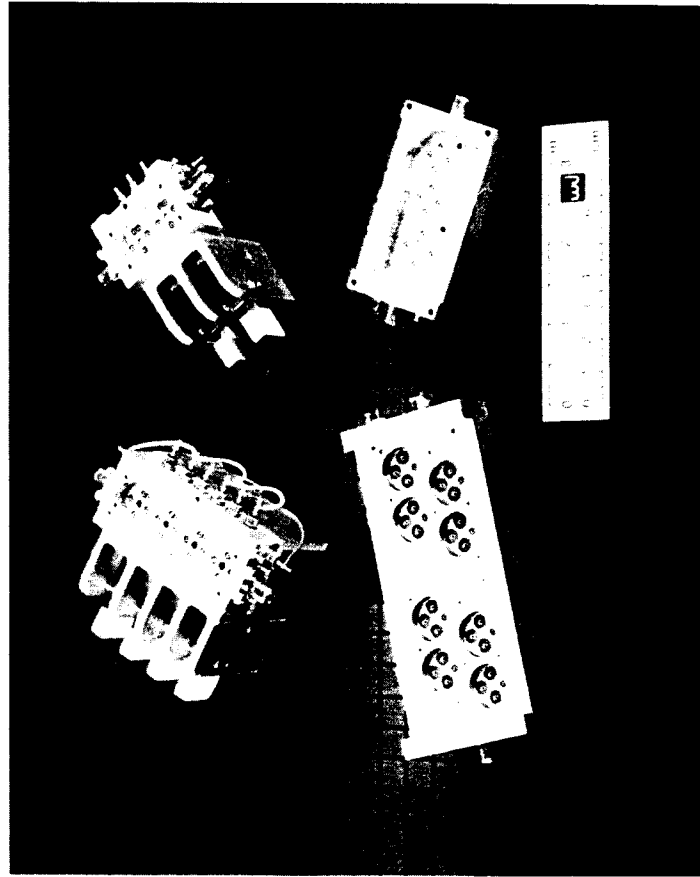

Figure 3. Cascaded test fixtures.

circuit is hermetically sealed) in a cascaded test fixture to enhance overall performance.

In addition to signal reflections caused by impedance mismatch, insertion loss is prevalent in all cascade assemblies. As a signal propagates through the conducting medium, a small portion is attenuated due to ohmic skin losses, mainly from the rf/trace conductor. These losses are inherent in the package assembly and are unrecoverable.

Other losses occur as a result of radiated emissions (radiated electromagnetic energy) from the propagating signal (see Figure 4) which are not fully contained in the dielectric substrate. The ineffectiveness of the substrate to isolate the signal from ground will result in more signal being absorbed in the housing cavity as loss. Therefore, the choice of dielectric material is important, especially at higher operating frequencies and at power levels where the radiation increases in intensity.

Generally, in the cascaded amplifier product line, G-10 fiberglass PWB (see Figure 5A) material ($\epsilon = 4.46$, G-10

thickness = .050 inches) performs well, up to 2.5 GHz. Above this level, there is too much loss associated with the cascaded assembly.

Cascaded amplifiers operating at higher frequencies are assembled using aluminum-backed Duroid™ printed-wiring boards ($\epsilon = 2.23$), because the thinner dielectric material (.010 inches) is proven to be less dispersive than G-10 fiberglass. Duroid PWB (see Figure 5B) material can be used in cascaded amplifiers up to 6.0 GHz, with good isolation.

Small-Signal Gain and Gain Flatness

Individual TO-8 amplifiers have limitations as to how much gain can be supplied. TO-8 package constraints generally allow room for up to three transistor stages utilizing either passive or active biasing with choke decoupling (depending on the model). The result is good broadband performance with 15.0 to 20.0 dB of small-signal gain. In applications where higher levels of gain are required (50.0 to 60.0 dB), an effective approach is to cascade these TO-8

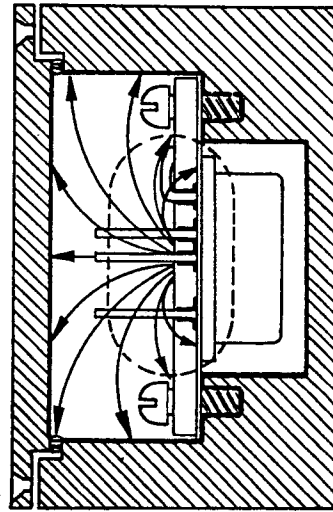

Solid Lines are Electric Field Lines

Dashed Line Represents a Magnetic Field Line.

Figure 4. Radiated emissions during rf operation.

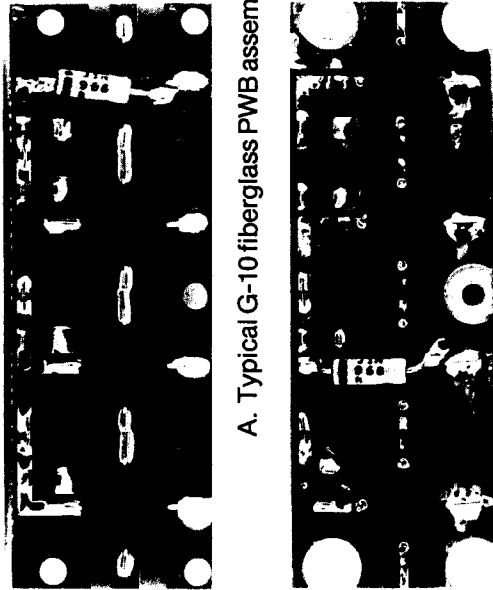

A. Typical G-10 fiberglass PWB assembly

B. Typical Duroid PWB assembly

Figure 5. Cascaded PWB assemblies.

amplifiers as "gain blocks," and assemble them into connectorized packages. In a typical cascaded amplifier, sets of two-to-eight TO-8 amplifiers can be assembled into one housing.

The total cascaded gain is the summation of the individual TO-8 gains. Here, the minimum level of gain within the operating frequency band of each TO-8 is added. The total gain, which is calculated from catalog data, will vary slightly from gain levels which are actually measured. This is due to TO-8 production runs exhibiting some variation in performance levels and deviation from the ideal 50-ohm environment.

The cascaded gain ripple or flatness is the difference between the minimum and maximum gain levels across the operating frequency band. The resultant shape is dependent on how well TO-8 amplifiers match in cascade to each other and the printed-wiring board assembly. Losses at high frequencies

play a major roll in overall cascaded gain response. Here, selecting TO-8 models with known gain responses will help optimize the cascaded gain response. For example, Figure 6A illustrates the frequency response of a WJ A31-1 amplifier.

The amplifier exhibits a characteristic gain "roll-up" at higher frequencies. Figure 6B illustrates the frequency response for the gain of a WJ RA36 amplifier. The high-end gain response inherently "rolls-off." Figure 6C illustrates the enhanced cascaded combination showing a flatter response with a desired high-end roll-up.

In a cascaded configuration, the rate of gain fluctuation over temperature is dependent on the resultant shape of the gain response and how well each TO-8 amplifier compensates for changes in temperature. With an amplifier exhibiting a high-end gain "roll-off" (more loss) at +25°C, an increase in temperature

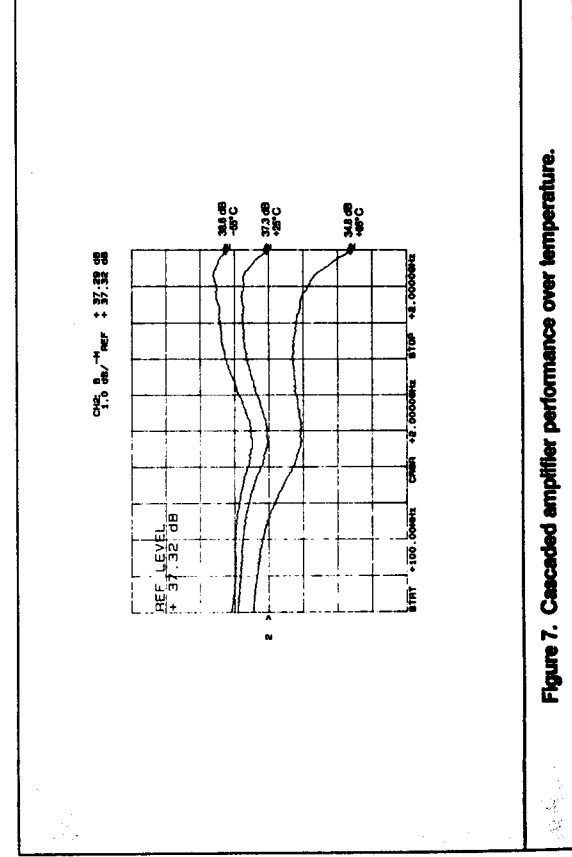
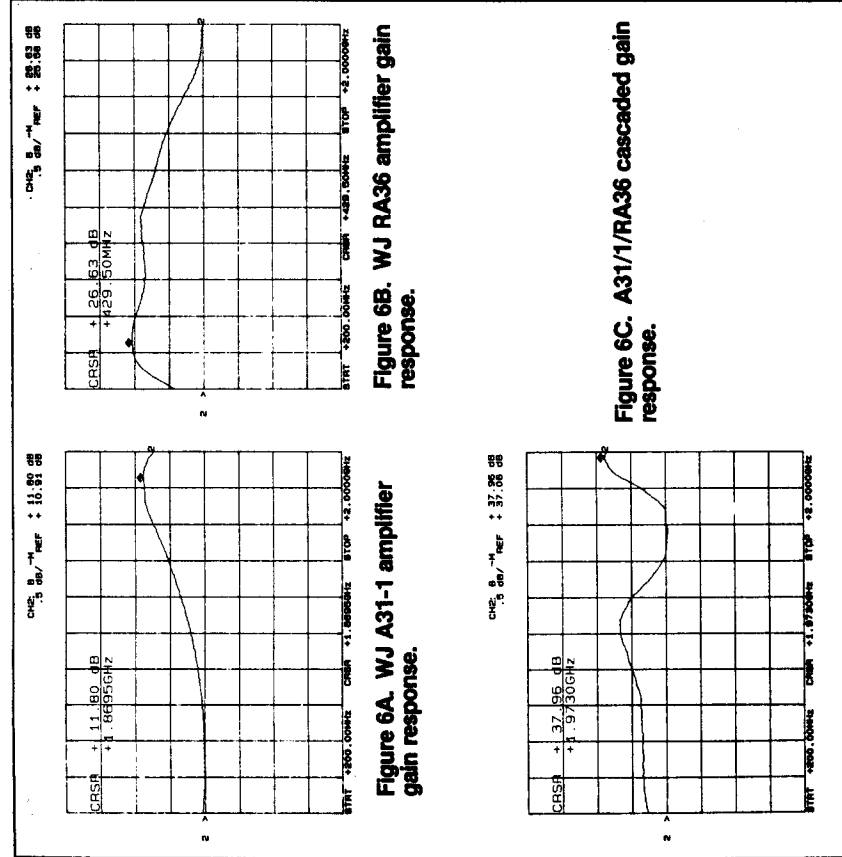

($\leq +85^{\circ}\text{C}$) will cause this portion to drop at a faster rate than at midband. As temperature decreases ($\geq -54^{\circ}\text{C}$), midband and high-end gain levels may rise 1.0 or 2.0 dB (See Figure 7). These variations are due to the elements in the rf feedback loops of the individual TO-8 amplifiers. The reactive elements, which manipulate the upper frequency response, are more sensitive to thermal variations than the resistive elements, which influence the low-end response.

The gain response will fluctuate and then stabilize as the temperature hits its minimum or maximum limit. The degree or speed of stabilization is dependent on which TO-8 models are used, incorporating either passive (fixed) or active (temperature-compensated) dc biasing for thermal stability, the latter being much more effective, since it directly alters the bias on the rf transistors.

In instances where more controlled stability is required for cascaded amplifiers which might be subjected to a restricted thermal-gain window, temperature-compensated circuitry can be integrated into the connectorized package.

In the cascaded amplifier standard product line, G-10 fiberglass PWB assemblies (see Figure 5A) are used over the temperature range of 0°C to $+50^{\circ}\text{C}$. Aluminum-backed Duriod PWB (see Figure 5B) is used in cascaded assemblies which draw high levels of current (>250 mA), and/or are exposed to extreme temperatures (-54°C to $+85^{\circ}\text{C}$). Unlike G-10, Duriod PWB assemblies are designed for thermal stress relief.

Input/Output VSWR

In a cascaded TO-8 amplifier chain, an incoming signal might be subjected to a higher degree of reflection loss than with a single TO-8 amplifier, since there

are more input/output matching networks with which to contend. More reflection loss causes more signal to be reflected back, which results in a higher voltage standing wave ratio (VSWR) and a reduction in the amount of power being transferred to the load. This makes the amplifier less efficient. Thus, the level of TO-8 input/output VSWR in cascaded amplifiers is mainly dependent on how well impedance levels of individual TO-8 amplifier ports match in relation to each other and the connectorized package.

Generally, in a cascade, the first-stage TO-8 input VSWR and last-stage TO-8 output VSWR make the largest contribution to overall I/O VSWR. TO-8s can be mixed and matched in a cascaded test fixture to optimize I/O VSWR levels.

Also, using a fixed-value attenuator (matched for 50 ohms) in front of the first stage of a cascade chain has the effect of lowering overall input VSWR because the reflected signal is attenuated. The only drawback is that the attenuator pad on the first stage lowers the gain and adds directly to the noise figure of the first-stage TO-8 amplifier, resulting in an overall degradation in cascaded gain and noise figure.

Similarly, a fixed-value attenuator used on the last stage of the cascade chain reduces the output and, to a lesser extent, the input reflected signals, which improves output VSWR. This is accomplished at the expense of reducing gain and output power by the amount of attenuation used.

In custom applications, individual TO-8 input/output matching networks can be tuned (at TO-8 preaseal) to optimize cascaded VSWR performance (5 to 4000 MHz I/O VSWR levels range from 1.1:1 to 2.5:1, maximum, over full operating temperatures).

Noise Figure

System applications require signals to be amplified with high levels of gain and driving power, but minimal interference from noise. In the Watkins-Johnson TO-8 product line, certain amplifier models have been designed for optimum noise figure (<3.0 dB at up to 4GHz). In a cascade of TO-8 amplifiers, the first-stage amplifier is usually the low-current, low-noise device, since it makes the largest contribution to the overall noise figure. In cascading additional stages to the first stage, noise power from these stages is added, but as a ratio of noise figure and gain from the previous stage (refer to Equation 1).

$$F_T = F_1 + \frac{F_2-1}{G_1} + \frac{F_3-1}{G_1 G_2} + \dots + \frac{F_n-1}{G_1 G_2 \dots G_{n-1}}$$

Equation (1)

F_n = stage noise figure,

G_n = stage gain,

n = stage number

Note: These calculations are performed using numeric values and the final result is converted to the noise figure in dB ($\text{dB} = 10 \text{ LOG } F_T$).

Each preceding stage thus makes less of a fractional contribution to the overall noise figure. Because of this, TO-8 amplifiers designed for high output power, which have high noise-figure levels (> 8.0 dB), are used on the last stage of the cascade.

Linear Operation

In cascaded amplifiers, small-signal linear gain is obtained by keeping input power levels in respective limits. These range from the minimum input signal level that can be detected above the cascade noise floor to 10.0 dB below the

1.0-dB compression power (discussed in the next section) of the cascade (see Figure 8). Also in this region, optimum VSWR and harmonic suppression are obtained.

To calculate the correct input power level for cascaded linear operation, the following formula can be used:

$$P_{IN} \text{ Linear} \leq \left[\begin{array}{l} P_{OUT} \text{ 1.0 dB compression power of the cascaded amplifier} \\ - \\ \text{small-signal gain of the cascaded amplifier} \\ -10 \text{ dB} \end{array} \right] \text{ Equation (2)}$$

Nonlinear Operation/1.0-dB Compression Power

Increasing input power levels to drive a cascaded amplifier out of the linear and into the nonlinear region of operation effectively causes the rf transistors in the individual TO-8 amplifiers to operate at their upper limits in a saturated condition. Linear gain compresses, and the device no longer operates at its optimum level.

Operation in the nonlinear region is done to obtain maximum power. The 1.0-dB compression power specifies the maximum power-handling capability of the device without significant intervention of intermodulation and harmonic distortion products. Figure 8 shows the 1.0-dB compression power to be the point where the amplifier small-signal gain is reduced by 1.0 dB. The following example illustrates how the 1.0-dB compression power is determined in a cascaded amplifier.

In the two-stage cascade shown in Figure 9, the total linear gain of the cascade

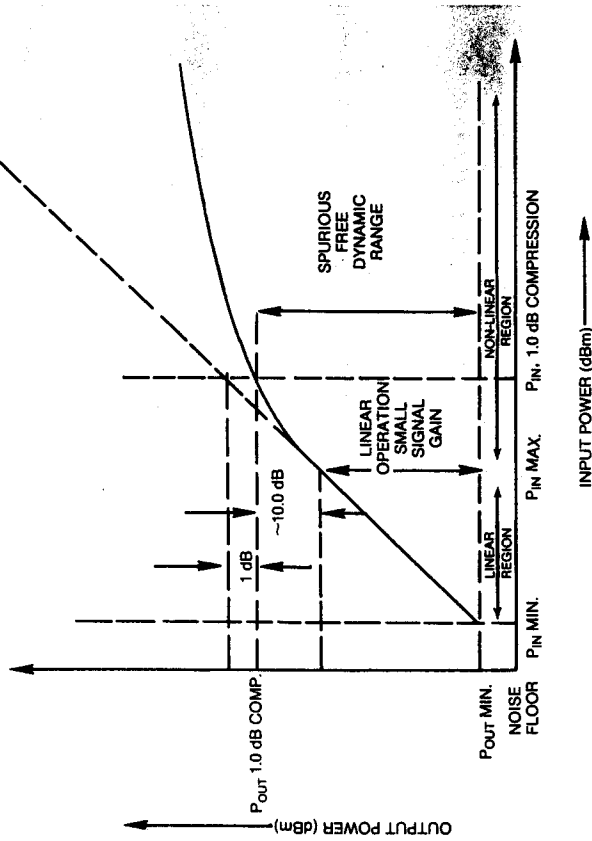

Figure 8. Linear/non-linear power response.

equals +22.0 dB and the 1.0-dB compression power is +15.6 dBm. The estimated input drive power necessary to reach the 1.0-dB compression point can be calculated from Equation 3:

$$P_{IN} \text{ [at 1.0 dB Comp. (dBm)]} = P_{OUT} \text{ [at 1.0 dB Comp. (dBm)]} - \text{Total cascaded gain (dB)} + 1.0 \text{ dB} \text{ Equation (3)}$$

Example using values of Figure 9.

$$P_{IN} \text{ [1.0 dB Comp. (dBm)]} = +15.6 \text{ dBm} - 22.0 \text{ dB} + 1.0 \text{ dB} = -5.4 \text{ dBm}$$

With -5.4 dBm input power applied to the A25-1, its output power will be approximately +8.1 dBm. This drive power being applied to the A27 will saturate the rf transistors, which results in the gain becoming compressed by 1.0 dB, giving +15.6 dBm of output power.

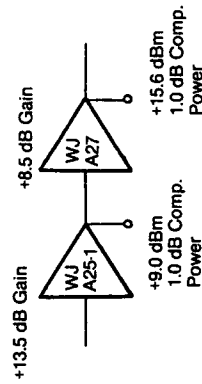

Figure 9. Two-stage amplifier cascade.

The region of operation between the minimum input signal level that can be detected above the noise floor and the 1.0dB compression point is the *dynamic range* of the cascade, where TO-8 amplifiers have "spurious-free" power gain (see Figure 8).

Distortion Products/Third-Order Intercept Point

Above the 1.0-dB gain compression point, rf transistors in the TO-8 amplifiers become saturated to a point where distortion products are amplified to levels that interfere with the signal response. These distortion products are an important consideration in cascaded amplifier design because the degree of

interaction puts limitations on the dynamic range.

When multiple signals (F1, F2) are amplified at high power levels (non-linear operation), spurious responses are generated which are at the single and multiple sum and difference frequencies.

Of the third-order products: 2F1 + F2, 2F2 + F1, 2F1 - F2, and 2F2 - F1; 2F1 - F2 and 2F2 - F1 can cause distortion within the operational bandwidths of most cascaded amplifiers.

The two-tone third-order intercept point is a measure of the level of these distortion products relative to the signal level

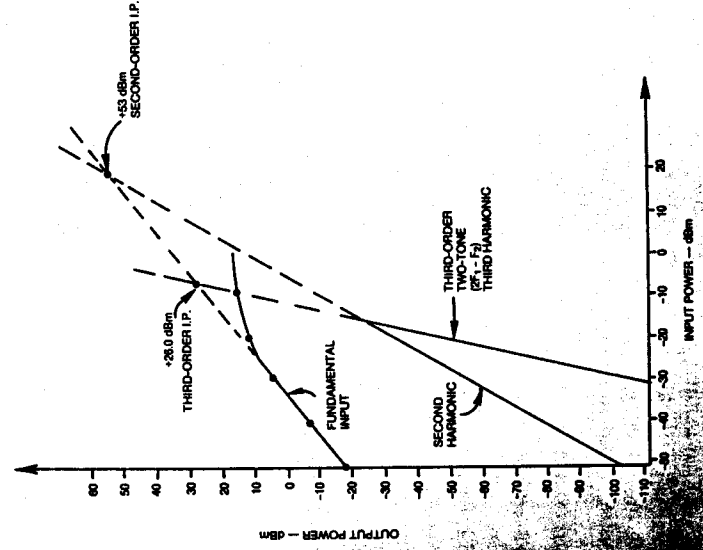
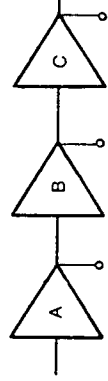

Figure 10. Output power vs. input power for the A31-1/A35/A37 cascaded amplifier.

(see Figure 10). The intercept point is measured at approximately 10.0 dB above the 1.0-dB compression power. At this third-order point, depending on the application, the maximum input power level can be determined which will not overdrive the amplifier to produce excessive spurious distortion.

When TO-8s are cascaded, the total cascaded 3rd-order intercept point is directly related to the individual TO-8 intercept points and their respective gains. In a multistage cascade, the last two stages are usually affected, since these are the higher power stages.

The following example shows that by using the dB-to-power ratio conversion formula (Equation 4) in conjunction with Equation 5, the third-order intercept point can be calculated for a cascaded amplifier.



Given:

- 1.) Amplifier C gain = 9.3 dB
- 2.) Amplifier C IP³ = 28.0 dBm or 640 mW
- 3.) Amplifier B IP³ = 21.0 dBm or 125 mW
- 4.) The formula:

$$\text{dB} = 10 \text{ Log } \frac{P_1}{P_2}$$

Equation (4)

Converting Equation 4 to the following form:

$$\frac{\text{dB}}{10} \text{ Log}^{-1} = \frac{P_1}{P_2}$$

Inserting the value for amplifier C gain:

$$\frac{9.3}{10} \text{ Log}^{-1} = 8.5$$

= Power ratio form for gain which is needed for equation 5.

Equation 5 is used to calculate the third-order intercept point.

$$\text{Cascaded IP}^{3^{-1}} = [(\text{IP}^3 \text{ B mW}) (\text{Gain C})]^{-1} + [\text{IP}^3 \text{ C mW}]^{-1}$$

Equation (5)

Using Equation 5 and inserting the required values, the cascaded third-order intercept point is calculated.

$$\text{Cascaded IP}^{3^{-1}} = [(125 \text{ mW}) (8.5)]^{-1} + [(640 \text{ mW})]^{-1}$$

$$\text{Cascaded IP}^{3^{-1}} = 400 \text{ mW} = 26 \text{ dBm} = \text{3rd-Order Intercept point}$$

Note: the mW to dB conversion can be done using Equation 4.

In this case, only a 2.0-dB degradation is expected by cascading, when comparing the last-stage intercept point of 28.0 dBm.

For quick estimating purposes, the following guidelines can be substituted for the calculation:

Note: The input 3rd-order intercept point of the last TO-8 stage is determined by using the following formula:

$$\text{IP}^3 \text{ Input} = \text{IP}^3 \text{ Output} - \text{small-signal TO-8 gain (last stage)}$$

Equation (6)

If the last-stage input intercept point equals the second-to-last stage output intercept point, a 3.0-dB degradation will result in the total cascade 3rd-order intercept point.

If the last-stage input intercept point is much greater than (> 6.0 dB) the second-to-last stage output intercept point, then a 1.0-dB degradation will result with the cascade 3rd-order intercept point. This is the ideal case for design purposes because the last stage is not being overdriven by an excessive amount of power.

If the last-stage input intercept point is much less than (< 6.0 dB) the second-to-last stage output intercept point, then degradation greater than or equal to the difference will result. This situation should be avoided, since the last stage TO-8 is being overdriven to the point where permanent damage could result.

Nonlinear Phase Distortion

Another cause of cascaded amplifier distortion is nonlinear phase distortion. A distortion-free signal requires phase, like gain, to be a linear function of fre-

quency. A linear phase shift produces a relatively constant group delay at different frequencies. In a nonlinear phase shift, the group delay changes with different frequencies. This can result in system degradation due to distortions in the signal response.

The level of phase distortion will increase as an amplifier or limiter runs further into saturation. A cascade of limiting amplifiers (usually eight TO-8 stages in a connectorized housing) is designed to limit a given range of input power to an output level, with minimal variance. There must be enough total gain so that the last-stage limiter can be driven into saturation at the lowest input power level. As the input power increases, more limiters in the cascade chain saturate and produce intermodulation distortion products which cause the phase response across the frequency band to shift and distort.

AM-to-PM conversion is a common type of phase distortion that can occur with limiting amplifiers. As the input signal becomes amplified, and power gets

(Continued on page 14)

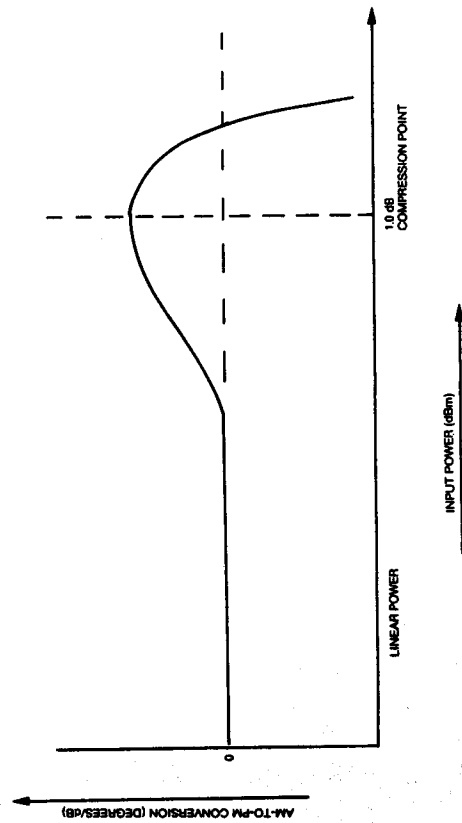
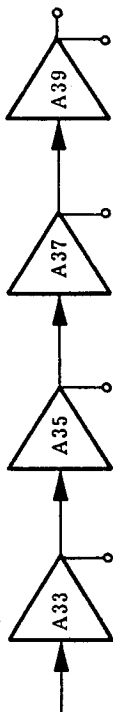

Figure 11. Typical AM-to-PM Conversion response.

Cascade Design Example:

WJ 6203-426 (A33/A35/A37/A39)

Conditions—Typical at +25°C 10 MHz to 2000 MHz.



	A33	A35	A37	A39
Gain, Min.	9.5 dB	10.2 dB	9.3 dB	7.5 dB
Gain Flatness, Typ.	±0.8 dB	±0.8 dB	±0.8 dB	±0.7 dB
Noise Figure, Typ.	4.5 dB	5.0 dB	6.5 dB	9.0 dB
Power 1.0 dB Comp., Typ.	3.0 dBm	9.0 dBm	15.5 dBm	22.0 dBm
IP ³ , Typ.	15.0 dBm	21.0 dBm	28.0 dBm	34.0 dBm
VSWR Input, Typ.	2.0:1	2.2:1	2.2:1	2.2:1
VSWR Output, Typ.	2.0:1	2.2:1	2.2:1	2.2:1
DC Current at +15 Vdc, Typ.	14.0 mA	24.0 mA	45.0 mA	90.0 mA

Total Cascaded Gain = 36.5 dB Min.

Total Gain Flatness = ±0.8 dB Typical

Cascaded Noise Figure: (see Equation 1)

$$= 4.5 \text{ dB} + \left(\frac{3.16 - 1}{8.91} \right) + \left(\frac{4.47 - 1}{93.3} \right) + \left(\frac{7.94 - 1}{794.1} \right)$$

$$= 4.5 \text{ dB} + 0.242 \text{ dB} + 0.037 \text{ dB} + 0.00874 \text{ dB} = 4.79 \text{ dB}$$

Input power level for linear operation (see Equation 2):

$$P_{\text{OUT}} \text{ 1.0-dB compression of the cascaded amplifier} = +22 \text{ dBm} + 22 \text{ dBm} - 36.5 \text{ dB} - 10.0 \text{ dB} = -24.5 \text{ dBm}$$

Input power level for 1.0-dB compression: (see Equation 3)

$$+22 \text{ dBm} - 36.5 \text{ dB} + 1.0 \text{ dB} = -13.5 \text{ dBm}$$

3rd-Order Intercept (Quick Estimate)

4th-stage input intercept point

$$34.0 \text{ dBm} - 7.5 \text{ dB} = 26.5 \text{ dBm}$$

3rd-stage output IP³ = 28.0 dBm

A 3-dB degradation will result

estimated cascaded IP³ = 31.0 dBm, typical

Note: The actual IP³ can be calculated using Equation 4

Cascaded input VSWR = 2.1:1 (measured)

Cascaded output VSWR = 2.1:1 (measured)

DC current at +15 VDC = 173 mA, typical

(Continued from page 12)

limited across the cascade chain, the resulting phase shift becomes a function of the instantaneous amplitude of the signal. The output phase response consists of a mean value plus a small phase ripple. The change in output phase per 1.0-dB increase in input power is the AM-to-PM conversion rate. Figure 11 illustrates how AM-to-PM conversion degrades as input drive power increases. In the linear region of operation, the change in phase per 1.0-dB increment is constant. As the drive level increases toward saturation, the output phase response changes at a greater rate than the 1.0-dB stepped input. The AM-to-PM conversion response usually peaks at the 1.0 or 2.0 dB compression point.

For a cascaded application, prior to printed-circuit board assembly, TO-8 limiting amplifiers like the WJ LA7, LA17, LA45, and LA45-1, are phase-matched in a test fixture to optimize phase linearity over frequency and minimize AM-to-PM conversion.

Conclusion

Developing a good understanding of cascaded amplifier design techniques and performance characteristics will aid in making the proper selection of individual TO-8 amplifiers for multi-stage applications.

Cascaded amplifiers operating in the frequency range of 200 kHz to 6.0 GHz offer much flexibility and performance with the benefit of being tailored for specific system applications, resulting in optimized system performance.

References

1. Gonzales, G., "Microwave Transistor Amplifiers—Analysis And Design." 1984, Prentice-Hall, Inc., Englewood Cliffs, New Jersey.
2. Neff, H., "Basic Electromagnetic Fields" 1981, Harper & Row, Publishers, New York N.Y.
3. Sedra & Smith, "Micro-Electronic Circuits" 1982, CBS College Publishing, New York, N.Y.
4. Cheadle, D., "Cascadable Amplifiers." Watkins-Johnson Company Tech-notes, February 1979, Vol. 6, No. 1.

AUTHOR

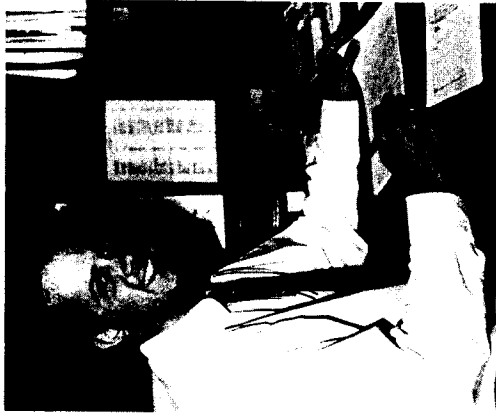

Timothy J. Galla

Mr. Galla is a Member of the Technical Staff with the Cascadable Amplifier Department, currently in the Amplifier Development Section. His project responsibilities include development and production of cascaded amplifiers and various integrated products, including mixer preamps operating up to 18.0 GHz. Mr. Galla holds a B.S.E.E. from San Jose State University.